

Mine dump truck BELAZ-75131 of payload capacity 130-136 tonnes

It's designed for transportation of rock mass in difficult mining and technical conditions of deep mines, at mineral deposit open pits on technological roads under various climatic operating conditions (at ambient temperature from -50 to +50 °C).



Engine

Model	CUMMINS KTA 50-C
Four-cycle gas-turbocharged and intercooled direct diesel engine with V-type cylinders arrangement and electronic control system.	
Rated power @ 1900 rpm, kW (hp)	1194(1600)
Maximum torque @ 1500 rpm, N.m	6292
Number of cylinders	16
Cylinders displacement, l	50,3
Cylinder diameter, mm	159
Piston stroke, mm	190
Specific fuel consumption at rated power, g/kW hr	207
Air cleaning is performed by three-stage filters with dry-type elements.	
Engine exhaust expulsion is performed through body.	
Circulating lubrication system is pressurized and designed with "wet" sump. Single-loop fluid cooling system with forced circulation.	
Fluid preheating system.	
Starting system is actuated by pneumatic starter.	
Electric equipment system voltage, V	24

Transmission

Transmission is equipped with alternating current - direct current drive with traction alternator, two traction motors, motorized wheels double-reduction units with spur gears, microprocessor-based control system and control devices, adjustment units.

Transmission ratio	30,36
Maximum dump truck travel speed, km/h	48

Traction alternator	GSN 500; GST-1; SGT-1000
Traction motor	EDP-600; EK-590; TED-6; ED-136; EK-420A

Suspension

Suspension is conventional for front axle and driving axle and equipped with trailing arms, central joints and transversal rods. Cylinders are pneumohydraulic (nitrogen and oil) and equipped with inbuilt hydraulic shock absorber. Two cylinders are on the front axle and two cylinders are on the rear axle.

Cylinder piston stroke, mm	
- front	320
- rear	290

Steering

Hydrostatic steering with steerable front wheels.

Steering angle, degree	42
Turning radius, m	13
Overall turning diameter, m	28
The steering meets ISO 5010 requirements.	

Brakes

Dump truck brake system meets ISO 3450 international safety regulations and requirements. The system is equipped with service, parking, auxiliary and emergency brake systems.

Service brake system is disk brakes with two brake gears per disk for front wheels and disk brakes with two brake gears per disk and automatic gap adjustment for rear wheels. The disks are mounted on traction motor shafts.

Parking brake system is permanently closed system with one brake gear of rear wheels per disk, spring actuator and hydraulic control.

Auxiliary brake system is electrodynamic braking by traction motors with forced air cooling of brake resistors (UVTR 2x600, power 1200 kW).

Emergency brake system uses parking brake and operable circuit of wheel brakes.

Hydraulic system

Hydraulic system is combined for body dumping gear, steering and brakes actuator. The system is equipped with variable-displacement axial-piston oil pump and three-stage telescopic body lifting cylinders with one stage of double action.

Body lifting time, s	20
Body lowering time, s	18
Maximum pressure in hydraulic system, MPa	18
Maximum pump delivery @ 1900 rpm, dm ³ /min	474
Filtration degree, mcm	10

Body

Welded bucket-type body with FOPS safety system, protective canopy, engine exhaust heating, device for mechanical fixing in raised position and rock-ejectors.

Body capacity, m³:

struck	heaped 2:1
40,0	67,0
45,5	71,2
50,1	75,5
55,0	80,0
59,6	84,0

Frame

Frame is welded of high-strength low-alloy steel with application of cast elements at the maximum loading points and equipped with box-section variable-height side-members interconnected by cross-members.



Tires

Tubeless air tires with quarry tread pattern.

Tire designation	33.00-51; 33.00R51
Inflation pressure, MPa	0,62; 0,7
Rim designation	24.00-51/5.0

Cab

Two-man two-door cab is equipped with air-sprung adjustable driver seat, additional trainee seat and adjustable steering column. The cab meets EN 474-1 and EN 474-6 requirements that specify permissible levels of in-cab noise, vibration, content of hazardous substances and dust.

Driver's workplace meets ROPS safety requirements.

In-cab noise level is not more than 80 dB(A).

Local vibration level is not more than 126 dB(A).

Overall vibration level is not more than 115 dB(A).

Special equipment

- Fire-fighting system (standard)
- Heating and conditioning unit (standard)
- Starting preheater (standard)
- Automatic lubrication system (optional)
- System of loading and fuel control (optional)
- Telemetering tire-pressure monitoring system (optional)
- Body floor lining (optional)
- Fast fueling system „Wiggins” (optional)
- Attention device of approach to high-voltage line (optional)
- Air purification system (optional)
- Air filters and fuel filters „Fleetguard” (optional)
- Additional bonnet (optional)
- Radio-recorder (optional)
- Air horn (optional)
- Electric clutch of fan drive EM-1500 (optional)

Overall dimensions, mm*

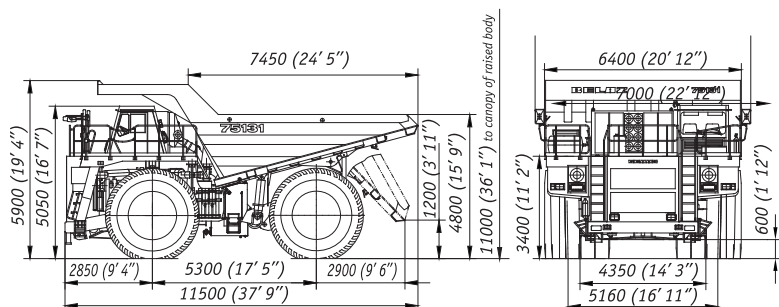

*Overall dimensions are specified for basic kitting-up of the dump truck

Weight

Maximum payload capacity of the dump truck equipped with:

- diagonal tires 33.00-51, kg	130000
- radial tires 33.00R51, kg	136000
Unladen weight, kg	107100

Gross weight of the dump truck equipped with:

- diagonal tires 33.00-51, kg	237100
- radial tires 33.00R51, kg	243100

Dump truck weight distribution on axles, %:

	unladen	laden
front	50,9	33,0
rear	49,1	67,0

Refill capacities, l

Fuel tank	1900
Engine cooling system	410
Engine lubrication system	195
Oil tank	490
Reduction units of motorized wheels	92(46x2)
Suspension cylinders:	
- front	33,8(16,9x2)
- rear	57,4 (28,7x2)

Towing and braking performance

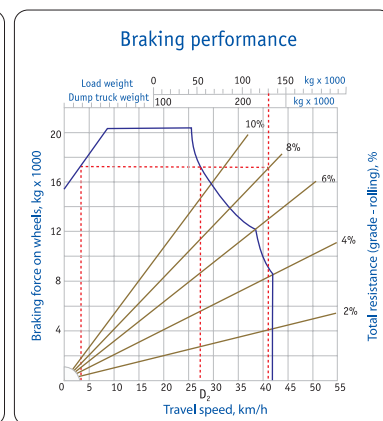
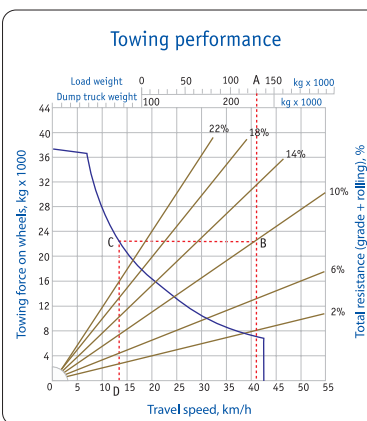

OJSC "Belarusian Autoworks" (BELAZ)
 40 let Oktyabrya str. 4, 222160, Zhodino, Republic of Belarus
 phone: +375 1775 3-60-67, 3-37-37, 3-27-82
 fax: +375 1775 7-01-37
 e-mail: office@belaz.minsk.by
 www.belaz.by